

ZESTAWY HYDROFOROWE DO PODNOSZENIA CIŚNIENIA

ZHF.9 - kołnierzyowy

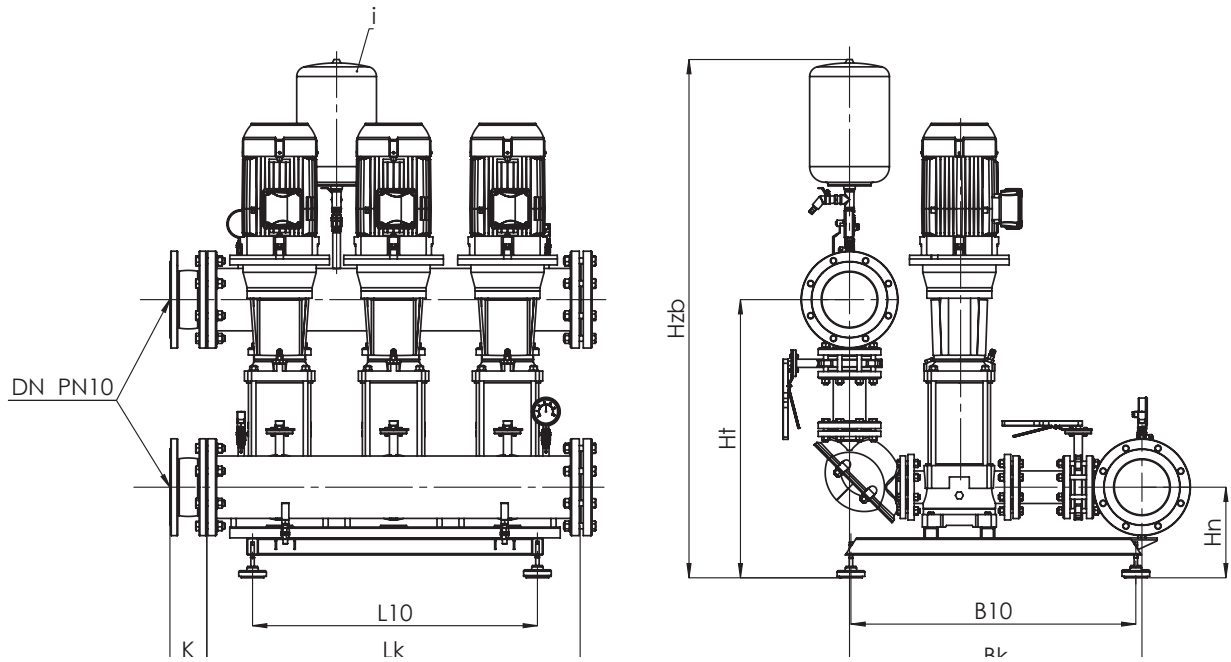

Typ zestawu	Moc [kW]	L k	L10	B10	B k	H n	H t	H zb	DN	i	Masa bez szafy
ZHF.9.A1.2	2 x 5,50	910	590	975	1030	320	980	1820	DN200	1	552
ZHF.9.A1.3	3 x 5,50	1300	1000	1000	1055	320	1005	1880	DN250	1	823
ZHF.9.A1.4	4 x 5,50	1700	1390	1030	1055	320	1005	1880	DN250	2	1066
ZHF.9.A1.5	5 x 5,50	2100	1790	1030	1080	360	1070	1970	DN300	3	1329
ZHF.9.01.2	2 x 7,50	910	590	975	1030	320	980	1820	DN200	1	559
ZHF.9.01.3	3 x 7,50	1300	1000	1000	1055	320	1005	1880	DN250	1	833
ZHF.9.01.4	4 x 7,50	1700	1390	1030	1055	320	1005	1880	DN250	2	1078
ZHF.9.01.5	5 x 7,50	2100	1790	1030	1080	360	1070	1970	DN300	3	1343
ZHF.9.B2.2	2 x 11,00	1010	690	975	1030	320	980	1820	DN200	1	627
ZHF.9.B2.3	3 x 11,00	1500	1200	1000	1055	320	1005	1880	DN250	1	922
ZHF.9.B2.4	4 x 11,00	2000	1700	1030	1055	320	1005	1880	DN250	2	1230
ZHF.9.B2.5	5 x 11,00	2500	2200	1030	1080	360	1070	1970	DN300	3	1518
ZHF.9.02.2	2 x 15,00	1010	690	975	1030	320	980	1820	DN200	1	634
ZHF.9.02.3	3 x 15,00	1500	1200	1000	1055	320	1005	1880	DN250	1	936
ZHF.9.02.4	4 x 15,00	2000	1700	1030	1055	320	1005	1880	DN250	2	1247
ZHF.9.02.5	5 x 15,00	2500	2200	1030	1080	360	1070	1970	DN300	3	1542
ZHF.9.B3.2	2 x 18,50	1010	690	975	1030	320	980	1820	DN200	1	693
ZHF.9.B3.3	3 x 18,50	1500	1200	1000	1055	320	1005	1880	DN250	1	1021
ZHF.9.B3.4	4 x 18,50	2000	1700	1030	1055	320	1005	1880	DN250	2	1360
ZHF.9.B3.5	5 x 18,50	2500	2200	1030	1080	360	1070	1970	DN300	3	1681
ZHF.9.03.2	2 x 22,00	1010	690	975	1030	320	980	1820	DN200	1	736
ZHF.9.03.3	3 x 22,00	1500	1200	1000	1055	320	1005	1880	DN250	1	1087
ZHF.9.03.4	4 x 22,00	2000	1700	1030	1055	320	1005	1880	DN250	2	1450
ZHF.9.03.5	5 x 22,00	2500	2200	1030	1080	360	1070	1970	DN300	3	1793